

CATÁLOGO

V 1.5

REEMPLAZA LA VERSIÓN 1.4



HIGH PERFORMANCE
INNOVACION TERMO MECANICA

www.itm.cl





SIN FRONTERAS

En ITM entregamos soluciones simples a problemas complejos en el área de climatización, Piping AC&R, IAQ & IEQ contando con equipos y soluciones de alta calidad y performance. Contando hoy en Chile con las representaciones más avanzadas y tecnológicas que podrán cumplir sus expectativas en cuanto a diseño y rendimiento.



ALEJANDRO RODAS LEIGH

CEO - Gerente General

REFRIGERACION



COUPLING



COUPLING REDUCER



ELBOW REDUCER



FLARE ADAPTER



TEE



45° ELBOW



05

BALL VALVE



CHARGE NIPPLE



SIGHT GLASS



SERVICE VALVES



XIP 1017÷3136



06

Crimping tool for DN2-4-6 ferrules



Equipo Refrigeración Split

MARSTAIR
REFRIGERATION AND SPECIALIST AIR CONDITIONING



17 Series
Cellar
Cooler

R410A

07

DRC (+) Ducted

MARSTAIR
REFRIGERATION AND SPECIALIST AIR CONDITIONING

Unidad Condensada para Ductos



08

Cellar Cooler Quick Selector

MARSTAIR
REFRIGERATION AND SPECIALIST AIR CONDITIONING

R410A



	Duty		m ³ Above		m ³ Below	
	8°C	12.7°C	8°C	12.7°C	8°C	12.7°C
CX(E)A 30 CKA 35	1.79	2.28	20	26	25	36
CX(E)A 50 CKA 35	3.06	3.25	27	38	44	63
CX(E)A 50 CKA 50	3.44	4.25	38	54	62	89
CX(E)A 70 CKA 70	4.54	5.60	54	78	88	125

Qualification of Cellar sizing

- Based on standard Cellar Construction
- Maximum product load 16 l/m³
- Product cooling time 24 hours (Nominal plant running time 18 hours)
- Product entering room 25°C





Evaporadores de cassette de co2 de 4 tubos con circuito de calefacción de gas caliente de co2. Una gama innovadora de cassettes proporcionados con un circuito de refrigeración por evaporador de co2 y un circuito de calentamiento de gas caliente de co2 específicamente diseñados para una refrigeración de confort.

APLICACIONES:

- *Co2 para áreas de preparación de alimentos a baja temperatura.*
- *Co2 para refrigeración, o refrigeración de confort.*
- *Gas caliente para calefacción utilizando calor recuperado del co2.*
- *Combinación de co2 y gas caliente para refrigeración y calefacción de confort.*

EQUIPOS CLIMATIZACIÓN

FANCOIL NORMA HOSPITALARIA

 biniclima®

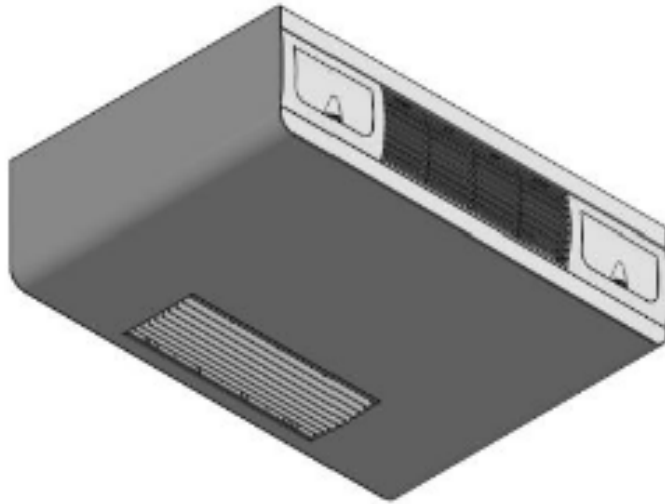

11

FB-I / FB-EC-I

 biniclima®

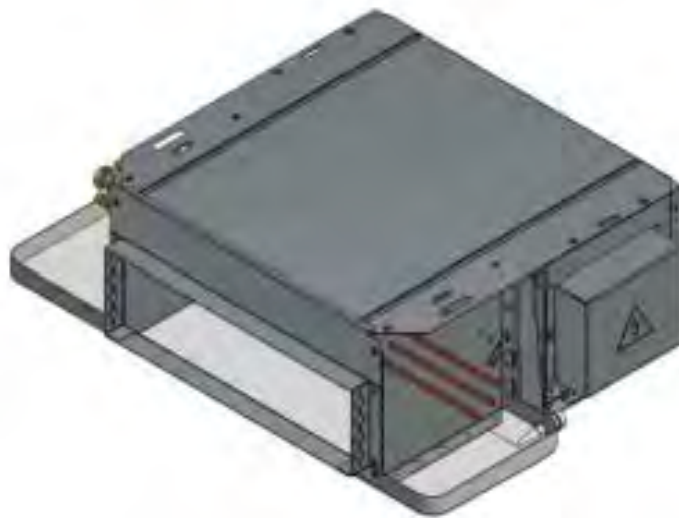

50 Hz Water-Source Heat Pumps



12

Equipos Condensados por agua 50HZ



CALEFACCIÓN

Soluciones Híbridas y sin Gas

IMMERGAS



14

Victrix superior 35

IMMERGAS



Ares 300 tec erp

IMMERGAS



15

Victrix hybrid

IMMERGAS



Magis m12

 IMMERGAS



16

Hydro in 1000

 IMMERGAS



Domestic sol 750 v2

IMMERGAS



17

luxor 33 v2

IMMERGAS



TORRES DE ENFRIAMIENTO

Torres de Enfriamiento

w.tech

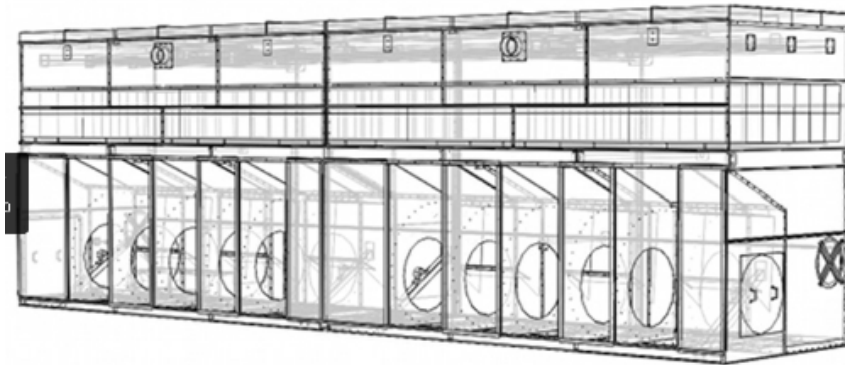

19

Torre de Enfriamiento con Ventilador Axial

w.tech



CONTROL Y AUTOMATIZACIÓN



HS-100-P

Detector de humo fotoeléctrico de aplicación especial hs-100 está diseñado para instalaciones en las que no se pueden utilizar detectores de ducto de montaje externo estándar. los ejemplos de aplicaciones incluyen sistemas de retorno de hvac, shafts de aire, espacios entre techos, dampers y aplicaciones que requieren una velocidad de aire extremadamente baja o nula (≤ 100 pies/min)



SL-2000-P

Detector de humo para ducto, del tipo fotoeléctrico

Detector para una instalación rápida, pruebas sin herramientas con la cubierta colocada y funciones de fácil mantenimiento. Se puede montar tanto en vertical como en horizontal.



SERIE STN-/STS-2.5 - 2.5` TUBE

STN son tubos metálicos con extremos entallados para uso con detectores SL-2000 y RT-3000.

Medidor Ultrasónico de Energía serie TUF

Dwyer

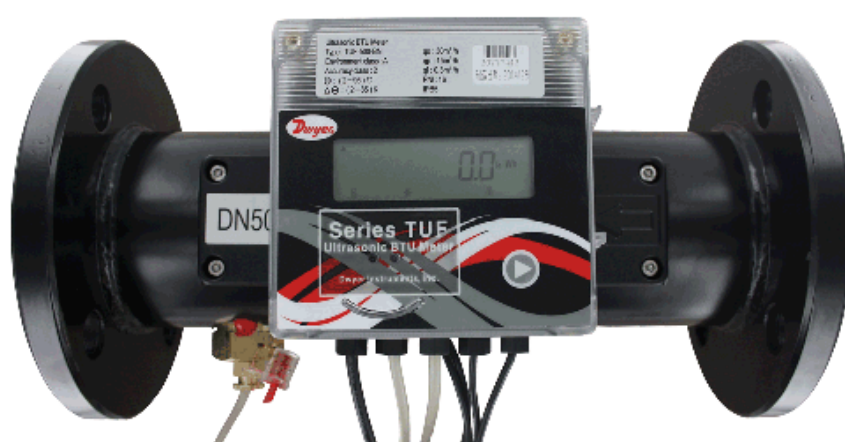

24

ACCESORIOS AGUA

Válvulas de Control PICV



MODELO 81



MODELO 83_PR



26

MODELO 91



MODELO 92



MODELO 93



MODELO 94 F





MODELO 51F



MODELO 52FROS



MODELO 52F





Metraloop® Expansion Joint

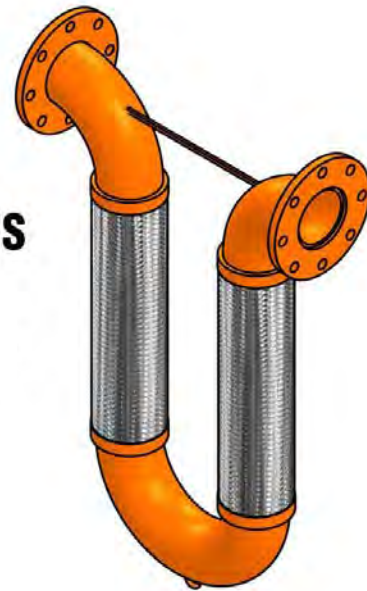
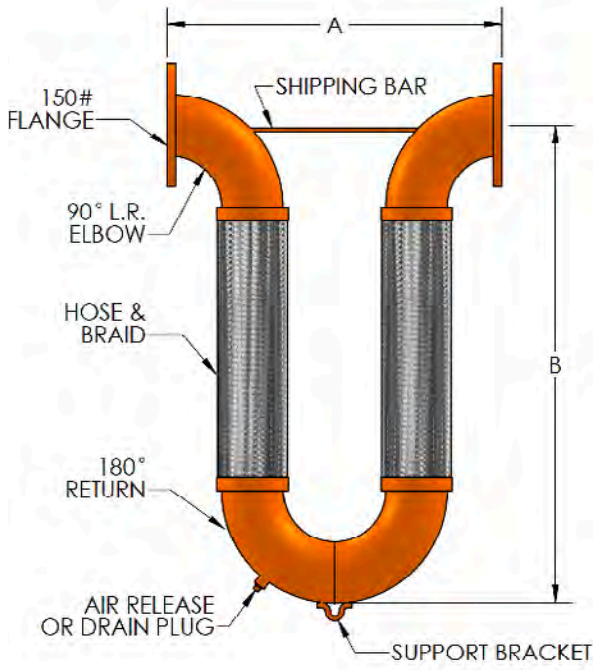

Fireloop® Seismic U-Loop Expansion

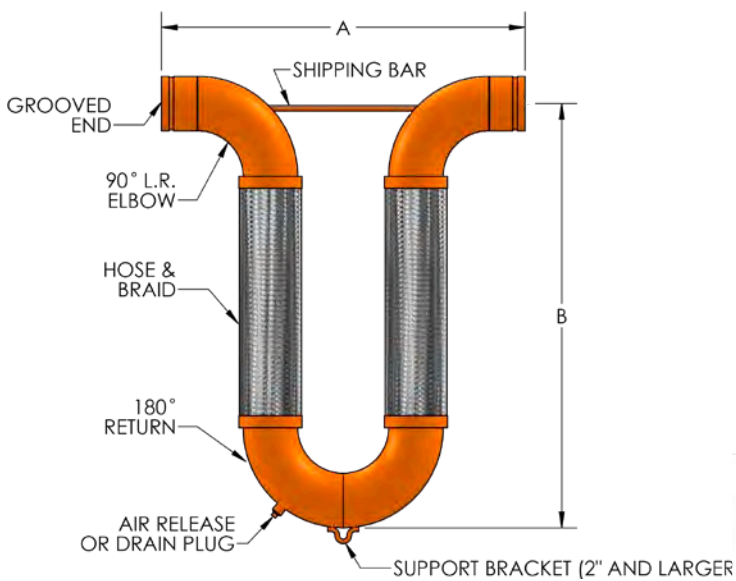

FOR FIRE SPRINKLER SYSTEMS

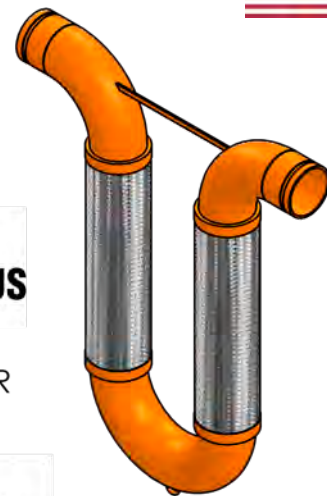

Seismic BreakAway Hanger (SBH)

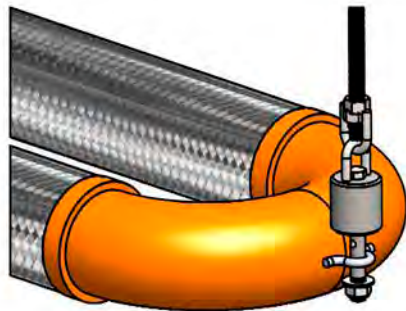

METRALOOP WITH SEISMIC BREAKAWAY HANGER
(FORMERLY BREAKAWAY COUPLING)



Manguitos Antvibratorios de Goma



UNA ONDA



DOBLE ONDA



SOLUCIONES
DE SANITIZADO
Y PURIFICACIÓN
MEDIO AMBIENTAL



PHI-PTAC Sistema de Purificación de Aire



33

PHI-PTAC

Sistema de purificación de aire

VIVIR EN ALTO RENDIMIENTO
ES HABITAR ESPACIOS SEGUROS LIBRE DE PARTÍCULAS DE POLVO, ÁCAROS, H1N1, MRSA, ESTAFILOCOCO, ESTREPTOCOCO, NOROVIRUS, LISTERIA Y MÁS.

El sistema de purificación de aire PHI-PTAC utiliza la tecnología patentada fotohidroionización® (PHI-CELL®) de RGF para reducir la contaminación del aire y las bacterias superficiales, los virus, los olores y las esporas de moho presentes en el aire. Está específicamente diseñado para unidades de aire acondicionado de tipo paquete (PTAC). PHI-PTAC se instala fácilmente en un sistema fan coil sin necesidad de modificarlo.



**IDEAL
PARA USO EN:**



34



HOSPITALES



EMBARCACIONES



TIENDAS



CASA Y
OFICINAS



HOTELES



SALA
CONFERENCIAS



RESTAURANTES



JARDINES
INFANTILES



AULAS

¿POR QUÉ USAR LA TECNOLOGÍA RGF PHI-CELL®?

La fotohidroionización (PHI) es una tecnología activa de tratamiento del aire.

El tratamiento activo del aire es el proceso de reducir los contaminantes del aire y de las superficies, al recrear los niveles naturales de peróxido de hidrógeno en el aire en las zonas ocupadas.



HIGH PERFORMANCE
INNOVACION TERMO MECANICA